

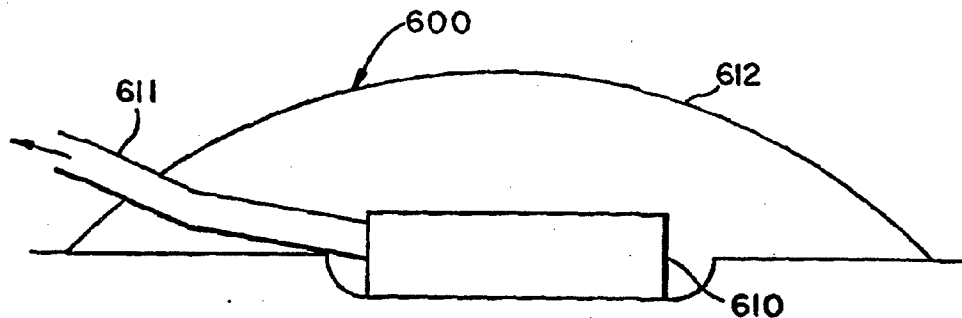

INTERNATIONAL APPLICATION PUBLISHED UNDER THE PATENT COOPERATION TREATY (PCT)

<p>(51) International Patent Classification⁵ : A61B 19/00</p>	<p>A1</p>	<p>(11) International Publication Number: WO 94/20041 (43) International Publication Date: 15 September 1994 (15.09.94)</p>
<p>(21) International Application Number: PCT/US94/02409 (22) International Filing Date: 7 March 1994 (07.03.94) (30) Priority Data: 08/028,677 9 March 1993 (09.03.93) US (60) Parent Application or Grant (63) Related by Continuation US 08/028,677 (CON) Filed on 9 March 1993 (09.03.93) (71) Applicant (for all designated States except US): WAKE FOREST UNIVERSITY [US/US]; The Bowman Gray School of Medicine, Office of Research Development, Medical Center Boulevard, Winston-Salem, NC 27157-1023 (US). (72) Inventors; and (75) Inventors/Applicants (for US only): ARGENTA, Louis, C. [US/US]; 525 Knob View Drive, Winston-Salem, NC 27104 (US). MORYKWAS, Michael, J. [US/US]; 6147 Spring Forest Drive, Pfafftown, NC 27040 (US).</p>	<p>(74) Agents: PIPER, Donald, R., Jr. et al.; Dann, Dorfman Herrell and Skillman, 1601 Market Street, Suite 720, Philadelphia, PA 19103-2307 (US). (81) Designated States: AT, AU, BB, BG, BR, BY, CA, CH, CN, CZ, DE, DK, ES, FI, GB, HU, JP, KG, KP, KR, KZ, LK, LU, LV, MD, MG, MN, MW, NL, NO, NZ, PL, PT, RO, RU, SD, SE, SI, SK, UA, US, UZ, VN, European patent (AT, BE, CH, DE, DK, ES, FR, GB, GR, IE, IT, LU, MC, NL, PT, SE), OAPI patent (BF, BJ, CF, CG, CI, CM, GA, GN, ML, MR, NE, SN, TD, TG). Published With international search report.</p>	

(54) Title: WOUND TREATMENT EMPLOYING REDUCED PRESSURE



(57) Abstract

A method of treating tissue damage comprises applying a negative pressure to a wound sufficient in time and magnitude to promote tissue migration and thus facilitate closure of the wound. The method is applicable to wounds, burns, infected wounds, and live tissue attachments. A wound treatment apparatus (600) is provided in which a fluid impermeable wound cover (612) is sealed over a wound site. A screen (610) in the form of an open cell foam screen or a rigid porous screen is placed beneath the wound cover (612) over the wound. A vacuum pump supplies suction within the wound cover (612) over the treatment site.

FOR THE PURPOSES OF INFORMATION ONLY

Codes used to identify States party to the PCT on the front pages of pamphlets publishing international applications under the PCT.

AT	Austria	GB	United Kingdom	MR	Mauritania
AU	Australia	GE	Georgia	MW	Malawi
BB	Barbados	GN	Guinea	NE	Niger
BE	Belgium	GR	Greece	NL	Netherlands
BF	Burkina Faso	HU	Hungary	NO	Norway
BG	Bulgaria	IE	Ireland	NZ	New Zealand
BJ	Benin	IT	Italy	PL	Poland
BR	Brazil	JP	Japan	PT	Portugal
BY	Belarus	KE	Kenya	RO	Romania
CA	Canada	KG	Kyrgystan	RU	Russian Federation
CF	Central African Republic	KP	Democratic People's Republic of Korea	SD	Sudan
CG	Congo	KR	Republic of Korea	SE	Sweden
CH	Switzerland	KZ	Kazakhstan	SI	Slovenia
CI	Côte d'Ivoire	LI	Liechtenstein	SK	Slovakia
CM	Cameroon	LK	Sri Lanka	SN	Senegal
CN	China	LU	Luxembourg	TD	Chad
CS	Czechoslovakia	LV	Latvia	TG	Togo
CZ	Czech Republic	MC	Monaco	TJ	Tajikistan
DE	Germany	MD	Republic of Moldova	TT	Trinidad and Tobago
DK	Denmark	MG	Madagascar	UA	Ukraine
ES	Spain	ML	Mali	US	United States of America
FI	Finland	MN	Mongolia	UZ	Uzbekistan
FR	France			VN	Viet Nam
GA	Gabon				

Wound Treatment Employing Reduced Pressure

Field of the Invention

The present invention relates to an apparatus and method for treating a wound by applying reduced pressure to the wound.

5

Background of the Invention

The treatment of open wounds that are too large to spontaneously close has long been a troublesome area of medical practice. Closure of an open wound requires inward migration of surrounding epithelial and subcutaneous tissue. Some wounds, however, are sufficiently large or infected that they are unable to heal spontaneously. In such instances, a zone of stasis in which localized edema restricts the flow of blood to the epithelial and subcutaneous tissue forms near the surface of the wound. Without sufficient blood flow, the wound is unable to successfully fight bacterial infection and is accordingly unable to close spontaneously.

An initial stage of wound healing is characterized by the formation of granulation tissue which is a matrix of collagen, fibronectin, and hyaluronic acid carrying macrophages, fibroblasts, and neovasculature that forms the basis for subsequent epithelialization of the wound. Infection and poor vascularization hinder the formation of granulation tissue within wounded tissue, thereby inhibiting wound healing. It therefore becomes desirable to provide a

technique for increasing blood circulation within wounded tissue to promote spontaneous healing and to reduce infection.

5 Poor blood circulation and infection at the wound may also hinder attachment of skin grafts or flaps upon wounded tissue. Skin grafts and flaps will not attach to tissue that is poorly vascularized, infected or necrotic. However, grafts and flaps can be used with much greater success on tissue that, although
10 wounded, is able to form granulation tissue. Accordingly, a technique for promoting blood circulation at the wounded tissue would also promote successful attachment, or "take," of skin grafts or flaps to the wounded tissue as a consequence of
15 increased blood circulation within the grafts or flaps.

Another problem encountered during the treatment of wounds is the selection of an appropriate technique for wound closure during the healing process. Sutures
20 are often used to apply force to adjacent viable tissue in order to induce the edges of a wound to migrate together and heal. However, sutures apply a closure force to only a very small percentage of the area surrounding a wound. When there is scarring,
25 edema, or insufficient tissue, the tension produced by the sutures can become great causing excessive pressure to be exerted by the sutures upon the tissue adjacent to each suture. As a result, the adjacent tissue often becomes ischemic thereby rendering
30 suturing of large wounds counterproductive. If the quantity or size of the sutures is increased to reduce the tension required of any single suture, the quantity of foreign material within the wound is concomitantly increased and the wound is more apt to
35 become infected. Additionally, the size or type of a

particular wound may prevent the use of sutures to promote wound closure. It therefore becomes desirable to provide an apparatus and method for closing a large wound that distributes a closure force evenly about
5 the periphery of the wound.

Wounds resulting from ischemia, or lack of blood flow, are also often difficult to heal since decreased blood flow to a wound may inhibit normal immune reaction to fight infection. Patients that are
10 bedridden or otherwise non-ambulatory are susceptible to such ischemic wounds as decubitus ulcers or pressure sores. Decubitus ulcers form as a result of constant compression of the skin surface and underlying tissue thus restricting circulation. Since
15 the patient is often unable to feel the wound or to move sufficiently to relieve the pressure, such wounds can become self-perpetuating. Although it is common to treat such wounds with flaps, the conditions that initially caused the wound may also work against
20 successful flap attachment. Wheelchair-bound paraplegics, for example, must still remain seated after treatment of pelvic pressure sores. It therefore becomes desirable to provide a treatment procedure for ischemic wounds that can be conducted in
25 situ upon an immobile or partially mobile patient.

Other types of wounds in which ischemia leads to progressive deterioration include partial thickness burns. A partial thickness burn is a burn in which the cell death due to thermal trauma does not extend
30 below the deepest epidermal structures such as hair follicles, sweat glands, or sebaceous glands. The progression of partial thickness burns to deeper burns is a major problem in burn therapy. The ability to control or diminish the depth of burns greatly
35 enhances the prognosis for burn patients and decreases

morbidity resulting from burns. Partial thickness burns are formed of a zone of coagulation, which encompasses tissue killed by thermal injury, and a zone of stasis. The zone of stasis is a layer of tissue immediately beneath the zone of coagulation. Cells within the zone of stasis are viable, but the blood flow is static because of collapse of vascular structures due to localized edema. Unless blood flow is re-established within the zone of stasis soon after injury, the tissue within the zone of stasis also dies. The death of tissue within the zone of stasis is caused by lack of oxygen and nutrients, reperfusion injury (re-establishment of blood flow after prolonged ischemia), and decreased migration of white blood cells to the zone resulting in bacterial proliferation. Again, it becomes desirable to provide a technique for treating burn wounds by enhancing blood circulation to the wounded tissue to inhibit burn penetration.

20

Summary of the Invention

In accordance with the present invention a wound treatment apparatus is provided for treating a wound by applying reduced pressure (i.e. pressure that is below ambient atmospheric pressure) to the wound in a controlled manner for a selected time period. The application of reduced pressure to a wound provides such benefits as faster healing, increased formation of granulation tissue, closure of chronic open wounds, reduction of bacterial density within wounds, inhibition of burn penetration, and enhancement of flap and graft attachment. Wounds that have exhibited positive response to treatment by the application of negative pressure include infected open wounds, decubitus ulcers, dehisced incisions, partial

35

thickness burns, and various lesions to which flaps or grafts have been attached.

5 The wound treatment apparatus in accordance with the present invention includes a reduced pressure application appliance which is applied to a treatment site at which there is a wound and normal tissue surrounding the wound. The reduced pressure application appliance includes a fluid impermeable wound cover for covering and enclosing the wound. The
10 appliance also includes sealing means for sealing the wound cover to the surrounding tissue of the wound in order to maintain reduced pressure in the vicinity of the wound during wound treatment. When the wound cover is sealed in position over the wound site, a
15 generally fluid-tight or gas-tight sealed enclosure is formed over the wound site. The sealing means may be in the form of an adhesive applied to the underside of the wound cover for sealing the wound cover around the periphery of the wound. The sealing means may also
20 include a separate sealing member such as an adhesive strip or a sealing ring in the form of a tubular pad or inflatable cuff secured to the wound cover for positioning around the periphery of the wound. In selected embodiments, the reduced pressure within the
25 sealed enclosure under the wound cover may serve to seal the wound cover in position at the wound site. The reduced pressure appliance also includes a suction port for supplying reduced pressure within the sealed volume enclosed beneath the wound cover. The suction
30 port may be in the form of a nipple on the wound cover. Alternatively, the suction port may be in the form of a tube attached to the wound cover or provided as a feedthrough beneath the wound cover. The appliance may also include a porous wound screen for
35 placement in the wound or in position overlying the

wound in order to prevent overgrowth of wound tissue during treatment. The wound screen is sufficiently porous to permit gas flow to the wound. The porous wound screen may be in the form of a sponge or open-cell foam material for placement in the wound. The porous screen may also include a rigid or semi-rigid screen for overlying the wound.

A vacuum system is connected with the reduced pressure appliance in order to provide suction or reduced pressure to the appliance. For this purpose, the vacuum system includes a suction pump or suction device for connection with the suction port of the appliance for producing the reduced pressure over the wound site. The vacuum system may include a section of hose or tube, such as a vacuum hose, that interconnects the suction device with the suction port of the appliance to provide the reduced pressure at the wound site. A collection device in the form of a fluid trap may be provided intermediate the vacuum hose of the suction device and the suction port of the appliance to trap any exudate which may be aspirated from the wound by the negative pressure appliance. A stop mechanism may also be provided for the vacuum system to halt production of the reduced pressure at the wound site in the event that an excessive quantity of exudate has been collected. The apparatus may also include a control device for controlling the pump and for providing intermittent or cyclic production of reduced pressure.

In a particular embodiment of the invention, the wound cover for the reduced pressure appliance may be in the form of a gas impermeable covering sheet of flexible polymer material, such as polyethylene, having an adhesive backing that provides the seal for securing the sheet over the wound site to provide an

gas-tight or fluid-tight sealed enclosure over the wound site. The vacuum system of the wound treatment apparatus may include a suction pump having a vacuum hose that is connected with a suction tube serving as
5 a suction port for the appliance. The suction tube for the appliance runs beneath the cover sheet that is sealed in position over the wound site and into the fluid-tight enclosure provided under the cover sheet. An adhesive backing on the cover sheet is used to
10 provide a fluid-tight seal around the feedthrough for the suction tube at the wound site. Within the enclosure, the suction tube is connected with a piece of open-cell foam for placement in the wound. The open-cell foam functions to more uniformly apply
15 reduced pressure or suction over the wound site while holding the cover sheet substantially out of the wound during the application of reduced pressure at the enclosed wound site.

In operation, a method of treating tissue damage
20 is provided which comprises applying a negative or reduced pressure to a wound over an area sufficient to promote the migration of epithelial and subcutaneous tissue toward the wound and for a time period sufficient to facilitate closure of the wound. The
25 method is useful for treating pressure sores.

A method of treating a burn wound is also provided which comprises applying a negative or reduced pressure to the burn over an area and for a
30 time sufficient to inhibit progression in the depth of the burn. The method is useful on a partial thickness burn soon after its infliction.

A method of treating tissue damage is also provided which comprises applying a negative or reduced pressure to a wound for a time sufficient to
35 reduce bacterial density in the wound. One use of

this method is its application to a wound for a selected time period such as at least three days to reduce the bacterial density of an infected wound to the point at which surgical closure can be attempted.

5 Another aspect of the invention is a method of enhancing the attachment of adjacent tissue to a wound which comprises applying negative or reduced pressure to a joined complex of the adjacent living tissue and the wound at a sufficient magnitude of reduced
10 pressure and for a sufficient time duration to promote the migration of epithelial and subcutaneous tissue toward the complex. This method enhances attachment of adjacent tissue to tissues of the wound edges. Another use of this method is to enhance attachment of
15 an open skin graft to the wound tissue.

Brief Description of the Drawings

The foregoing summary, as well as the following detailed description of the preferred embodiments of
20 the present invention, will be better understood when read in conjunction with the appended drawings, in which:

FIG. 1 is a schematic elevational view of a wound treatment apparatus in accordance with the present
25 invention in which a reduced pressure appliance, shown in partial section, includes a flexible, fluid impermeable wound cover sealed over the wound and a foam wound screen positioned in the wound, and in which a vacuum system provides reduced pressure within
30 the wound cover of the appliance;

FIG. 2 is a schematic sectional elevational view of a reduced pressure appliance in accordance with another embodiment of the present invention having a rigid, fluid impermeable wound cover sealed over a
35

wound and a rigid or semi-rigid screen overlying the wound;

5 FIG. 3 is a schematic sectional elevational view of a reduced pressure appliance in accordance with another embodiment of the present invention having a rigid, fluid impermeable wound cover sealed over a wound;

10 FIG. 4 is a schematic sectional elevational view of a reduced pressure appliance in accordance with another embodiment of the present invention having a semi-rigid, fluid impermeable cover enclosing a wound and a rigid or semi-rigid screen overlying the wound, with an overlying flexible fluid impermeable cover sheet sealing the enclosure over the wound;

15 FIG. 5 is a schematic elevational view of a reduced pressure appliance, shown in partial section, in accordance with another embodiment of the present invention having a flexible, fluid impermeable wound cover over an inner rigid porous support cup;

20 FIG. 6 is a schematic elevational view of a reduced pressure appliance, shown in partial section, having a rigid outer frame with support legs for supporting a flexible, fluid impermeable sealing cover over a wound;

25 FIG. 7 is a schematic elevational view in partial section of an alternative fluid collection device having a float valve for use in the vacuum system of FIG. 1;

30 FIG. 8 is a schematic view of an alternative vacuum system;

35 FIG. 9 is a schematic view of an alternative vacuum system incorporating a fluid collection device having an actuator for de-activating the vacuum system upon collection of a predetermined quantity of fluid;

FIG. 10 is a schematic cross-sectional view of a reduced or negative pressure appliance comprising an open-cell polymer foam screen, a flexible hose for connecting the foam screen with a vacuum system, and
5 an adhesive-backed flexible polymer sheet overlying the foam-hose assembly to provide a seal over a wound; and

FIG. 11 is a schematic cross-sectional view of a reduced or negative pressure appliance comprising a
10 rigid porous screen for a wound, a rigid or semi-rigid cup for covering the wound having an inflatable cuff attached about the base of the cup, and a flexible hose extending from the cup for connection with a vacuum system.

15

Detailed Description of the Preferred Embodiments

In accordance with the present invention, a wound treatment apparatus is provided for treating a wound by application of reduced pressure (i.e., below
20 atmospheric pressure) so that suction may be applied to a wound site in a controlled manner for a selected time period. As schematically shown in Fig. 10, a wound treatment apparatus includes a reduced pressure appliance, generally designated 600, which is applied
25 to a wound site to treat the wound through the application of reduced pressure. The appliance 600 is sealed in position over the wound site to create a generally fluid-tight or gas-tight enclosure over the wound site.

30 The appliance 600 includes a substantially flat section of open cell polyester foam section 610 (Fischer Scientific, Pittsburgh, PA 15219) sufficiently large to cover the wound and thus prevent wound overgrowth, a flexible hollow tube 611 (Fischer
35 Scientific) inserted into the open cell foam section

610 and joined thereto with an adhesive and extending to attach at its opposite end with a Gast Vacuum pump (Fischer Scientific), and an Ioban adhesive sheet 612 (Minnesota Mining and Manufacturing, St. Paul, MN 55144) overlying the foam section 610 and tubing 611 and adhered to the skin surrounding the wound, thus forming a seal that allows creation of a vacuum when the suction pump operates. Such an appliance 600 would most preferably be packaged in a sterile condition to ameliorate the need for sterilization of the apparatus prior to use. The adhesive sheet 612 may be packaged separately from the foam-tube assembly 610 and 611. A particular advantage of this configuration is its use with pressure sores because the device can be placed in the depths of the wound and the patient can lie upon the device without either affecting the utility of the device or further damaging the wound. This becomes critical if the patient cannot be moved from this posture for medical or other reasons.

As shown in FIG. 11, a reduced pressure appliance, generally designated 615, in accordance with another embodiment of the present invention, is schematically depicted. The reduced pressure appliance 615 includes an adult CPR mask 620 (Doug Brown and Associates, Huntington Beach, CA 92648) comprising a rigid or semi-rigid fluid impermeable cup 621 having an inflatable cuff 622 mounted around the periphery of the base of the cup 622 for contact with the skin, an open cell polyester screen 624 overlying the wound, and a flexible 1/4 inch diameter hose 623 (Fischer Scientific) connected by a Nalgene tubing connector extending through a sealed hole in the cup for connection with a vacuum pump (Fischer Scientific). The hose 623 is connected with the pump

40 of a vacuum system 30 of the type shown in FIG. 1 to provide reduced pressure within the cup 621. The vacuum created within the cup 621 by the vacuum system may be sufficient to seal the cup in position over the wound site. Alternatively, fluid impermeable adhesive covering or strips may also be used to seal the appliance 615 in proper position.

Referring to FIG. 1, a wound treatment apparatus, generally designated 25, is depicted having a reduced pressure appliance 29 for enclosing a wound site to provide a fluid-tight or gas-tight enclosure over the wound site to effect treatment of a wound 24 with reduced or negative pressure. The wound treatment apparatus 25 includes a reduced pressure appliance, generally designated 29, which is applied to and sealed over a wound site in order to enclose the wound site for treatment with suction or reduced pressure within a sealed generally fluid-tight or gas-tight enclosure. For the purpose of creating suction within the appliance 29, the appliance 29 is connected with a vacuum system, generally designed 30, to provide a source of suction or reduced pressure for the sealed appliance 29 at the wound site. The appliance 29 includes a fluid-impermeable wound cover 18 in the form of a flexible, adhesive, fluid impermeable polymer sheet for covering and enclosing the wound 24 and the surrounding normal skin 22 at the wound site. The wound cover 18 includes an adhesive backing 20 which functions to seal the wound cover to the normal skin 22 around the periphery of wound 24 to provide a generally gas-tight or fluid-tight enclosure over the wound 24. The adhesive cover sheet 18 must have sufficient adhesion to form a fluid-tight or gas-tight seal 19 around the periphery of the wound and to hold the sheet 18 in sealed contact with the skin during

the application of suction or reduced or negative pressure.

5 The appliance 29 also includes a porous wound screen 10 which is placed within the wound 24. The wound screen 10 is placed over substantially the
10 expanse of the wound to prevent its overgrowth. The size and configuration of the wound screen 10 can be adjusted to fit the individual wound. It can be formed from a variety of porous materials. The material should be sufficiently porous to allow oxygen
15 to reach the wound. The wound screen 610 may be in the form of an open-cell polymer foam, such as a polyurethane foam, which is sufficiently porous to allow gas flow to and/or from the wound 24. Foams may be used that vary in thickness and rigidity, although
20 it may be desirable to use a spongy material for the patient's comfort if the patient must lie upon the appliance during treatment. The foam may also be perforated to enhance gas flow and to reduce the weight of the appliance. As shown in FIG. 1, the
25 screen 10 is cut to an appropriate shape and size to fit within the wound 24. Alternatively, the screen may be sufficiently large to overlap the surrounding skin 22.

25 The appliance 29 also includes a suction port in the form of a hollow suction tube 12 that connects with the vacuum system 30 to provide suction within the sealed enclosure. The suction tubing 12 serves as a suction port for appliance 29. An end segment 12a
30 of the tubing 12 is embedded within the foam screen 10 for providing suction or reduced pressure within the enclosure provided under the wound cover 18. Embedding the open end of segment 12a of tubing 12
35 within the interior of the foam screen 10 permits the foam screen 10 to function as a shield to help prevent

the wound cover 18 from being inadvertently sucked into sealing engagement with the open end of the tube thereby plugging the tube 12 and restricting gas flow. The tube segment 12a embedded within the foam screen

5 10 preferably has at least one side port 14 for positioning within the interior of the foam screen 10 to promote substantially uniform application of reduced pressure throughout the enclosure. Positioning the side port 14 of tube segment 12a

10 within the interior of the foam screen 10 permits the foam screen 10 to function as a shield for the side port to thereby prevent the wound cover 18 from being sucked into the side port 14 and thereby restricting gas flow. The open cells of the foam screen 10

15 facilitate gas flow throughout the enclosure. In addition, the foam screen 10 functions to prevent wound overgrowth and to hold the wound cover 18 generally out of contact with the wound 24 during the application of suction within the enclosure.

20 Tubing 12 and tube segment 12a are sufficiently flexible to permit movement of the tubing but are sufficiently rigid to resist constriction when reduced pressure is supplied to the appliance 29 or when the location of the wound is such that the patient must

25 sit or lie upon the tubing 12 or upon the reduced pressure appliance 29. The screen-tube assembly comprising the foam screen 10 and the tube 12 may be fabricated by snaking the end of the tube segment 12a through an internal passageway in the foam screen 10

30 such as by pulling the end of the tube segment 12a through the passageway using forceps. Alternatively, fabrication of the screen-tube assembly may be accomplished by suspending the end of the tube segment 12a into a suitable mold or form and then blowing foam

35 into the mold or form to embed the tube end segment

12a within the blow-molded foam screen. The screen-tube assembly 12 and 10 is preferably prepared prior to use under sterile conditions and then stored in an aseptic package.

5 In order to use the reduced pressure appliance 29 at the site of the wound 24, the flexible, gas-impermeable, adhesive wound cover sheet 18 is secured in position at the wound site overlying the foam screen 10 disposed within the wound 24. The wound
10 cover sheet 18 is secured and sealed to the surrounding normal skin 22 by an adhesive layer 20 on the under surface of the wound cover 18 to form a gas-tight seal 19 around the periphery of the wound 24. The wound cover 18 also provides a gas-tight seal
15 around the tubing 12 at the feedthrough location 22a where the tubing 12 emerges from beneath the wound cover 18. The wound cover 18 is preferably formed of a fluid impermeable or gas impermeable flexible adhesive sheet such as Ioban, a product of the 3M
20 corporation of Minneapolis, Minn.

 The vacuum system 30 includes a suction pump 40 that produces a source of reduced pressure or suction which is supplied to the reduced pressure appliance 29 by suction tubing 12. As shown in FIG. 1, a fluid
25 trap, generally designated 28, is interconnected between the suction pump 40 and the appliance 29 to remove and collect any exudate which may be aspirated from the wound 24 by the reduced pressure appliance. The appliance 29 functions to actively draw fluid or
30 exudate from the wound 24. Collection of exudate in a fluid trap 28 intermediate the pump 40 and the appliance 29 is desirable to prevent clogging of the pump 40. A suitable fluid trap 28 may be assembled from an Erlenmeyer or side-arm flask 31 having a top
35 opening and a side-arm opening. The fluid trap 28

includes a first port 32 at the top opening of the flask for sealed connection to suction tubing 12. The first port 32 enables suction to be applied to the reduced pressure appliance 29 through the tubing 12 and also enables exudate from the wound covered by reduced pressure appliance 29 to be drained into the flask 31. The flask 31 provides a collecting vessel 33 for the fluid trap for containing and temporarily storing the collected exudate. A suction port 34 is provided at the side-arm opening of the flask to enable the application of suction from vacuum pump 40. The suction port 34 of the fluid trap 28 is connected to the vacuum pump 40 by vacuum line 36. The fluid trap 28 is sealed generally gas-tight to enable the suction pump 40 to supply suction to the appliance 29 through the fluid trap 28. A filter 38 such as micropore filter is preferably attached to the exhaust of the pump 40 to prevent potentially pathogenic microbes or aerosols from being vented to atmosphere by the vacuum pump 40.

Predetermined amounts of suction or reduced pressure are produced by the vacuum pump 40. The vacuum pump 40 is preferably controlled by a control device 44 such as a switch or a timer which may be set to provide cyclic on/off operation of the vacuum pump 40 according to user-selected intervals. Alternatively, the vacuum pump 40 may be operated continuously without the use of a cyclical timer.

The vacuum system 30 preferably includes a shut-off mechanism for halting or inhibiting the supply of the reduced pressure to the appliance 29 in the event that the exudate aspirated from the wound 24 exceeds a predetermined quantity. Interrupting the application of suction to the appliance 29 is desirable to prevent exsanguination in the unlikely event a blood vessel

ruptures under the wound cover 18 during treatment. If, for example, a blood vessel ruptures in the vicinity of the wound 24, a shut-off mechanism would be useful to prevent the vacuum system 30 from
5 aspirating any significant quantity of blood from the patient. As a safety feature, various mechanical or electrical detection mechanisms may be employed to detect the level of exudate in the fluid trap 28.

As shown in FIG. 7, a fluid trap 28 employing a
10 collection bottle or flask 35 is provided for connection intermediate the pump 40 and the appliance 29 for collecting exudate from the wound site. The flask 35 has a side-arm port 43 connected to suction tube 12 leading to the reduced pressure appliance 29
15 and a suction port 34 located at the top 44 of the flask 35 connected to the vacuum hose 36 leading to the vacuum pump 40. For the purpose of detecting liquid level within the flask 35, a float valve assembly, generally designated 39, is provided. The
20 float-valve assembly 39 functions to close and seal off the suction port 34 of the fluid trap 28 when the quantity of exudate in the collecting vessel 33 exceeds a predetermined quantity. The float valve assembly 39 is provided in the form of a ball 46 which
25 is held and suspended within a cage 47 positioned below a valve seat 48 disposed within the opening at the top 44 of the flask 35. The ball 46 has a specific gravity below that of the exudate so that the ball 46 will float upon the exudate and will be lifted
30 against the valve seat 48 as the vessel 33 fills with exudate. When the ball 46 is firmly seated against the valve seat 48, the float valve 39 blocks suction port 34 and thereby shuts off the source of suction from vacuum line 36. The suction within the appliance
35 29 at the wound site arrests thus halting the

aspiration of exudate from the wound.

Other types of mechanisms may be employed to detect the liquid level within the fluid trap 28 in order to arrest operation of the vacuum source. An
5 alternative vacuum system 30a is shown in FIG. 8 in which a filter 38a is employed in vacuum line 36 for filtering the fluid or gas flow through the vacuum line 36 and for detecting the level of liquid in fluid trap 28. Exudate from the wound is collected in
10 vessel 33. When the vessel 33 becomes full, aspiration of further exudate from the wound causes the vacuum line 36 to begin to collect exudate which eventually reaches the in-line filter 38a positioned in the vacuum line 36 intermediate the fluid trap 28
15 and the pump 40a having operational control 44a. The filter 38a contains a filter element that is selected to clog when exposed to sufficient amounts of moisture to thereby halt the supply of suction through the fluid trap 28 to the appliance 29. The filter 38a is
20 preferably an in-line, disc-shaped submicron filter having a nitrocellulose or PTFE filtration element for filtering particles larger than about $.1\mu\text{m}$ from the vacuum line 36. In addition to preventing excess fluid aspiration, the filter 38a in the vacuum line 36
25 prevents contamination of the vacuum pump 40 by filtering potentially pathogenic microbes and aerosols.

Other types of detection devices may also be employed to detect a predetermined level of liquid
30 collected in collection vessel 33. For example, collection of exudate in excess of a predetermined quantity may enable actuation of an electronic switch which turns off the vacuum pump or otherwise halts the supply of suction to the reduced pressure appliance
35 29. Referring to FIG. 9, the suction tubing 12 from

the reduced pressure appliance 29 is connected to a three-port coupling device 160 that interconnects suction tube 12, vacuum line 36b and fluid collecting apparatus 131. The coupling device 160 permits

5 transmission of suction from the vacuum line 36b of the pump 40b to the suction tubing 12. The coupling device 160 also permits aspirated exudate from tubing 12 to be collected in an expandable container, such as an intravenous fluid bag 162, housed beneath the

10 coupling device 160 in a rigid housing vessel 33b. As exudate is collected, the bag 162 expands to conform to the shape of the interior surface of the surrounding rigid vessel 33b. An actuator 166, such as a spring-loaded actuator switch, is located within

15 the side wall of the rigid vessel 33b and functions to shut off the pump 40b upon actuation of the switch 166. When the bag 162 expands sufficiently to contact and actuate switch 166 as shown in dashed lines at 162a in FIG. 9, the switch 166 is opened and the

20 supply of power to the pump 40b along power line 164 is interrupted and the supply of suction to the appliance 29 is stopped. The actuator switch 166 may also cooperate with control 44b for the pump 40b to stop operation of the pump 40b. Other types of

25 devices may also be employed to detect fluid levels in fluid trap 28. For example, weight detectors may be employed to detect a predetermined weight limit as the fluid trap fills with exudate or other liquid. Alternatively, optical sensors or detectors may also

30 be employed.

For the purpose of protecting the site of a wound from impact or abrasion during treatment, a reduced pressure appliance employing a rigid or semi-rigid wound cover may be utilized over the site of the

35 wound. As shown in FIG. 2, a reduced pressure

appliance 29a includes a CPR mask 58 that provides a rigid wound cover for enclosing an appropriately-sized wound 74. The mask 59 is impermeable to fluids or gases so that a fluid-tight or gas-tight enclosure is effected over the wound site. The mask 59 is sufficiently rigid to support itself away from the wound during the application of suction or reduced pressure so that the mask 59 does not collapse into the wound 74. The CPR mask 58 is of the type having an inflatable air cuff 59 around the base of the mask. The cuff 59 may be inflated via an external valve for sealing the mask 59 against the normal skin 72 around the periphery of the wound 74. The air cuff 59 also prevents the base of the mask from digging into the skin 72 during application of reduced pressure. An optional screen 50 for preventing overgrowth of the wound 74 may be positioned to overlie the wound 74. The screen 50 may be formed of a rigid or semi-rigid perforated polymer surgical mesh such as Prolene mesh. Alternatively, a section of honeycombed polyethylene sheet may be cut to a suitable size and shape to overlie the wound 74. The screen 50 is held against the surrounding normal skin 72 in position overlying wound 74 by the cuff 59 which overlaps at least a portion of the periphery of the screen 50. The CPR mask 58 also includes a suction port in the form of a hose connector 54 to which one end of a suction tube 52 is attached. The other end of tube 52 is connected with a vacuum system 30 of the type previously described to provide a source of suction or reduced pressure for the appliance 29a. Suction produced within the appliance 29a may be sufficient to seal the cuff 59 to the skin and to thereby seal the appliance 29a in position over the wound site. However, in order to ensure a gas-tight seal between the reduced

pressure appliance 29a and the surrounding skin 72, the mask 58 may also be secured to the treatment site with a fluid impermeable adhesive seal 68. The adhesive seal 68 may be formed of a flexible adhesive material such as an adhesive tape or an adhesive sheet that has been cut to surround and at least partially overlie the cuff 59. As shown in FIG. 2, the adhesive seal is secured to the base portion of the rigid mask 58 and to the normal skin 72 around the periphery of the air cuff 59 to seal the mask in position over the wound site.

As shown in FIG. 3, a reduced pressure appliance 29b is depicted having a rigid, fluid impermeable, cup-shaped wound cover 88 overlying a wound site. The appliance 29b is used to treat a wound 114 without any screen either in the wound or overlying the wound. The cover cup 88 can be formed of a polymer such as polystyrene, HDPE, or other suitably rigid material. The cup 88 must be sufficiently rigid to support itself out of contact with the wound 114 during the application of suction or negative pressure so that the cup 88 does not collapse into the wound. Reduced pressure is supplied to the interior of the cup 88 through the suction tubing 82 connected to suction port 84 in the form of a nipple sealed in position on the cup 88. The tubing 82 is also connected with a suitable vacuum system 30 of the type previously described to provide a source of suction or negative pressure within the appliance 29b. The base of the cup 88 supports an inflatable air cuff 89 to seal the cup 88 to the skin and to prevent the cup 88 from digging into the skin 92 and causing discomfort when reduced pressure is applied. The cuff 89 is positioned upon the normal skin 92 surrounding the wound 94. While the suction created within the cup 88

may be sufficient to hold the appliance in position by causing the air cuff to seal to the skin, more effective attachment of the appliance to the surrounding skin 92 may be obtained by the use of a
5 strip of fluid impermeable, adhesive material secured to the skin 102 and to the base of the cup 88 over the air cuff 89 around the periphery of the base of the cup 88. The layer of adhesive material 98 helps to ensure that a fluid-tight or gas-tight seal is
10 maintained between the cup 88 and the surrounding skin 92 so that a fluid-tight enclosure is formed over the wound site.

Referring to FIG. 4, a reduced pressure appliance 29c is depicted for enclosing a wound site for the
15 treatment of wound 114 with suction or reduced pressure. The reduced pressure appliance 29c includes a fluid-impermeable wound covering, generally designated 116, having an outer flexible, adhesive polymer sheet 117 applied over an inner, generally
20 circular, semi-rigid shield 118, such as a polystyrene shield, for covering and enclosing the wound site. The base of the shield 118 is positioned over a circular pad 109 which may be formed from flexible tubing to prevent the base of the cup from digging
25 into the skin 102 and causing discomfort when suction is applied to the appliance 29c. The pad 109 may also facilitate sealing of the cover shield 118 in position over the wound site to form a fluid-tight or gas-tight enclosure over the wound site. The pad 109 may be
30 positioned directly onto the normal skin 102 surrounding the wound 114 or, as shown in FIG. 4, the pad 109 may overlie an outer peripheral portion of a rigid screen 100 in order to hold the screen 100 in a position overlying the wound to prevent wound
35 overgrowth. A suction port 104 is provided at the top

of the shield 118 to permit gas-tight connection to suction tube 112. The suction port 104 may be in the form of a removable connector that is screwed into position at the top of the shield 118. Suction tube 5 112 functions to connect the appliance 29c to a suitable vacuum system 30 of the type previously described. For the purpose of enhancing the sealing of the appliance 29c in position over the wound site, an over-sized, generally circular, adhesive, fluid 10 impermeable polymer sheet 117 is adhered and secured to the top surface of the shield 118. The oversized adhesive sheet 117 extends beyond the outer periphery of the shield 118 so that the adhesive sheet 117 provides a sealing ring 119 of material around the 15 periphery of the shield. The sealing ring 119 is sealed and adhered to the normal skin 102 around the outer periphery of pad 109. When sealed in position overlying wound 114, the appliance 29c provides a generally fluid-tight or gas-tight enclosure over the 20 wound site.

Referring to FIG. 5, a reduced pressure appliance 29d is depicted for enclosing and treating a wound 124 with suction or reduced pressure. A rigid or semirigid porous cup 138 is placed rim side down upon 25 a porous screen or pad 120 located within a wound 124. The cup 138 has perforations 133 for equalizing pressure inside and outside of the cup 138. A flexible, fluid impermeable adhesive polymer cover sheet 128 is draped over the cup 138 to enclose the 30 wound 124. The adhesive cover sheet 128 is adhered and sealed to the top portion of the cup 138 and to the surrounding normal skin 122 by adhesive layer 129 on the underside of the cover sheet 128 to provide a fluid-tight enclosure beneath the sheet 128. The cup 35 138 provides a generally central support beneath the

cover sheet 128 to hold the cover sheet 128 out of contact with the wound 124 during application of suction. The cup 138 has a central suction port 134 sealed in position at the top of the cup 128 to permit
5 connection by suction tube 132 to a vacuum system 30 of the type previously described. When reduced pressure is supplied to the appliance 29d, the cover sheet 128 is deformed downward and inward to position 128a as shown in phantom in FIG. 5. Tension developed
10 within the deformed sheet 128a by virtue of the suction is exerted upon the surrounding skin by the sheet at position 128a. The outer periphery 124a of the wound 124 is pulled inward by virtue of such tension to the position shown in phantom at 124b to
15 promote closure of the wound. The tension within the sheet at position 128a also exerts a downward force upon the cup 138 which more firmly presses the cup 138 onto the wound 124. Such downward force on the cup 138 may be desired in such applications as flap or
20 graft attachment to promote contact between the flap or graft and the underlying tissue. The pad 124 under the cup 138 helps to alleviate discomfort caused by the downward force on the cup 138.

For applications where a downward pressure of the
25 appliance into a wound is not desired, a reduced pressure appliance 29e, as shown in FIG. 6, may be utilized having a support structure, generally designated 151, which is positioned external to a flexible sealing sheet 148 for covering a wound 144.
30 The flexible cover sheet 148 is in the form of a flexible, fluid impermeable, adhesive polymer sheet. The reduced pressure appliance 29e shown in FIG. 6 includes an external support frame 151 in the form of a series of spider-like legs 158 radiating outwardly
35 from a central support hub 155. The legs 158 hold the

central hub 159 directly over the wound 144. A connector 153 is removably mounted to the hub 155 to permit a suction tube 152 to be connected with the flexible cover sheet 148. The connector 153 may screw together and apart to permit the connector to be removably mounted relative to the hub 155. The flexible adhesive sheet 148 is adhered to the connector 153 at hub 155 and to the surrounding normal skin 142 so that the sheet is suspended over the wound 144 from the hub 155 in tentlike fashion. The flexible sheet is adhesively sealed to the connector 153 at the hub 155 and is also adhesively sealed to the skin 142 around the periphery of the wound 144 to form a fluid-tight or gas-tight enclosure over the wound site. The legs 158 of the frame 153 extend radially outward from the hub 153 and stand upon feet members 159 which may rest upon the outer periphery of the sheet 148 to help hold the cover sheet 148 in a position from being sucked together during the application of suction. Alternatively, the feet members 159 may extend beyond the cover sheet 148 and may rest upon the surrounding tissue beyond the periphery of the cover sheet 148. The connector 153 supported on the hub 155 provides a suction port 154 through which suction is supplied to the appliance 29e via suction tube 152. Tube 152 is connected to a vacuum system 30 of the type previously described for supplying reduced pressure within the cover sheet 148. When suction or reduced pressure is introduced via port 154, the sheet 148 deforms inwardly and downwardly to the position shown in phantom at 148a thus developing tension which is exerted upon the surrounding skin 142. The deformed sheet in position at 148a pulls the edges of the wound 144 inwardly to the position indicated in phantom at 144b hence

promoting closure of the wound 144.

Negative pressure appliances are useful for treating a variety of wounds. Treatment of a wound can be carried out by securing a negative pressure
5 appliance to the treatment site as previously shown and described, and then maintaining a substantially continuous or cyclical reduced pressure within the appliance until the wound has reached a desired
10 improved condition. A selected state of improved condition may include formation of granulation tissue sufficient for the attachment of a flap or graft, reduction of microbial infection in the wound, arrest or reversal of burn penetration, closure of the wound, integration of a flap or graft with the underlying
15 wounded tissue, complete healing of the wound, or other stages of improvement or healing appropriate to a given type of wound or wound complex. It may be preferable to change the appliance periodically, such as at 48 hour intervals, during treatment,
20 particularly when using appliances incorporating a screen on or in the wound. The method is preferably practiced using a negative or reduced pressure ranging from 0.01 to 0.99 atmospheres, and more preferably practiced using a negative or reduced pressure ranging
25 between 0.5 to 0.8 atmospheres. The time period for use of the method on a wound may preferably be at least 12 hours, but can be, for example, extended for one or more days. There is no upper limit beyond which use of the method is no longer beneficial; the
30 method increases the rate of closure up to the time the wound actually closes. Satisfactory treatment of various types of wounds has been obtained via the use of reduced pressures equivalent to about 2 to 7 in. Hg below atmospheric pressure.

35

Supplying reduced pressure to the appliance in an intermittent or cyclic manner has also been demonstrated to be useful for treating wounds. Intermittent or cyclic supply of reduced pressure to an appliance may be achieved by manual or automatic control of the vacuum system. A cycle ratio, the ratio of "on" time to "off" time, in such an intermittent reduced pressure treatment may be as low as 1:10 or as high as 10:1. The preferred ratio is approximately 1:1 which is usually accomplished in alternating 5 minute intervals of reduced pressure supply and non-supply.

A suitable vacuum system includes any suction pump capable of providing at least 0.1 pounds of suction to the wound, and preferably up to three pounds suction, and most preferably up to fourteen (14) pounds suction. The pump can be any ordinary suction pump suitable for medical purposes that is capable of providing the necessary suction. The dimension of the tubing interconnecting the pump and the reduced pressure appliance is controlled by the pump's ability to provide the suction level needed for operation. A 1/4 inch diameter tube may be suitable.

The present invention also includes a method of treating damaged tissue which comprises the steps of applying negative pressure to a wound for a selected time and at a selected magnitude sufficient to reduce bacterial density in the wound. Open wounds are almost always contaminated with harmful bacteria. Generally a bacterial density of 10^5 bacterial organisms per gram of tissue is regarded as infected. It is generally accepted that at this level of infection, grafted tissue will not adhere to a wound. These bacteria must be killed, either through the wound host's natural immune response or through some

external method, before a wound will close. The application of negative pressure to a wound appears to reduce the bacterial density of the wound. It is believed that this effect is due to either the

5 bacteria's incompatibility with a negative pressure environment or the increased blood flow to the wound area, as blood brings with it cells and enzymes to destroy the bacteria. The method can be used to reduce bacterial density in a wound by at least half.

10 More preferably, it can be used to reduce bacterial density by at least 1,000 fold. Most preferably, the method can be used to reduce bacterial density by at least 1,000,000 fold.

The present invention also includes a method of

15 treating a burn which comprises the steps of applying negative pressure to the burn over an area with predetermined reduced pressure and for a time sufficient to inhibit formation of a full thickness burn. A partial thickness burn, one which has a

20 surface layer of dead tissue and an underlying zone of stasis, is often sufficiently infected so that it will transform within 24-48 hours into a full thickness burn, one in which all epidermal structures are destroyed. The application of negative pressure to

25 the wound prevents the infection from becoming sufficiently severe to cause destruction of the underlying epidermal structures. The magnitude, pattern, and duration of pressure application can vary with the individual wound.

30 The present invention also provides a method for enhancing the attachment of living tissue to a wound which comprises the steps of first joining the living tissue to the wound to form a wound-tissue complex, then applying a negative or reduced pressure of

35 selected magnitude to the wound-tissue complex over an

area sufficient to promote migration of epithelia and subcutaneous tissue toward the complex, with the negative pressure being maintained for a selected time period sufficient to facilitate closure of the wound.

5 Attachment of living tissue to a wound is a common procedure that can take many forms. For example, one common technique is the use of a "flap," a technique in which skin tissue from an area adjacent to the wound is detached on three sides but remains attached

10 on the fourth, then is moved onto the wound. Another frequently used technique is an open skin graft in which skin is fully detached from another skin surface and grafted onto the wound. The application of negative pressure to the wound-graft complex reduces

15 bacterial density in the complex and improves blood flow to the wound, thereby improving the attachment of the grafted tissue. Further features of the apparatus and methods for the use thereof shall be made apparent in the following examples.

20

Example 1 - Treatment of Open Wounds

In order to demonstrate the use of a negative pressure appliance in the treatment of open wounds, an animal study was conducted using pigs as subjects.

25 Pigs are frequently used as subjects in wound healing studies since they have essentially the same skin and subcutaneous tissue structure as humans.

Five 15 kg Chester pigs were obtained and acclimated for 1 week prior to use. The animals were

30 sedated with an intramuscular injection of ketamine (25 mg/kg): xylazine (2.5 mg/kg): acepromazine (5 mg/kg). The backs and sides of the animals were shaved and scrubbed for surgery. One percent halothane was administered by endotracheal tube for

35 maintenance of anesthesia. Two circular wounds were

created on the midline of the animals. The wounds were 2.5 cm in diameter having a depth reaching, but not including, the deep fascia over the spine (approximately 1 cm). Wounds in pigs in this site do
5 not contract during healing. Alginate impressions were made of each wound to determine the volumes of the wounds.

A reduced pressure appliance of the type discussed in connection with FIGS. 2 and 11 was
10 positioned over each wound, and the cups were sealed to the skin with an Ioban sheet. A non-compressible silicone tube was attached to the anterior appliance of each pig and a reduced pressure of 5 in. Hg below atmospheric pressure was supplied to the anterior
15 appliances. No reduced pressure was applied to the posterior wounds. The animals were allowed to recover from anesthesia and given food and water *ad libitum*. The tubes were suspended from a pulley system over the top of each pen arranged to provide each animal with
20 full, unrestricted access to its pen.

The animals were sedated 48 hours after surgery as described above, and then daily thereafter, so that alginate impressions could be made of each wound. This routine was continued until the wounded areas
25 were filled with granulation tissue until coplanar with the surrounding tissue. The results of this experiment, including time to complete filling of the wound space by granulation tissue and the rate of granulation tissue formation, are presented in Table
30 1. The data in the third column of Table 1 shows the number of days needed for the treated and non-treated wounds to heal. In order to allow comparisons between the healing rate of variously-sized wounds, the data in the fourth column is expressed as a healing rate in
35 terms of cc granulation tissue per day. As can be

seen, the treated wounds exhibited higher rates of healing than did the non-treated wounds. The wounds treated with reduced pressure filled with granulation tissue at an average rate that was 52.3% greater than the rate of granulation of the control wounds. Animals numbered 1 and 2 experienced intermittent loss of reduced pressure throughout the experiment, yet the treated wounds of these animals also healed significantly faster than their control wounds.

TABLE 1

Animal	Wound	Initial Wound Volume (cm ³)	Days to Full Granulation	Fill Rate (cm ³ /day)	% Rate Increase Due to Treatment
#1	Control	4.9	13	0.38	
	Treated	5.3	11	0.48	26.3
#2	Control	7.2	8	0.90	
	Treated	9.3	8	1.16	28.9
#3	Control	4.0	12	0.33	
	Treated	3.5	6	0.58	75.8
#4	Control	4.7	11	0.43	
	Treated	5.0	7	0.71	65.1
#5	Control	4.7	11	0.43	
	Treated	5.1	7	0.71	65.1
Average	---	---	---	---	52.3

Example 2 - Reduction of Infection

During the course of the experiment described as Example 1 above, it was observed that the reduced pressure-treated wounds were much cleaner and bled more spontaneously than non-treated wounds. It was therefore undertaken to determine the relative rates of clearance of a known bacterial inoculum from treated and non-treated wounds.

Five 15 kg pigs were obtained and wounds created as set forth in Example 1. Two 2.5 cm diameter defects were created on the dorsum of each pig using a sterile technique, with a 7.5 cm interval retained between the edges of the defects. Hemostasis was obtained by electrocautery. Prior to placement of the reduced pressure appliances, 10⁸ organisms of

Staphylococcus aureus in 1 ml saline solution were injected into each wound. The reduced pressure appliances of the type shown in FIGS. 2 and 11 were then attached as in Example 1, and a reduced pressure of 5 in. Hg below atmospheric pressure was applied to one of the wounds upon each animal. Reduced pressure was not applied to the other wound upon each animal. T-shirts were placed over the animals and no antibiotics were given during the course of the study. The animals were sedated as in Example 1 at 24 hour intervals, and a 3 mm diameter full thickness biopsy was taken from each wound site daily. The devices were then reattached and reduced pressure re-applied. This routine was continued for one week.

The biopsy samples were weighed and sterile saline (99X biopsy weight) added. The tissue samples were homogenized in a tissue grinder and serial dilutions were made in triplicate. 100 microliters of each dilution was plated on a blood agar plate and incubated overnight. The number of colonies were counted on each plate and thus the number of organisms per gram of tissue was calculated. The data was recorded as the common logarithm of the number of organisms/gram tissue and is shown in Table 2.

TABLE 2

Average Log₁₀(organisms/gm).

	Day 0	Day 1	Day 2	Day 3	Day 4	Day 5	Day 7
Control	8.44	8.04	8.17	7.13	7.13	8.82	7.08
Treated	7.69	7.36	7.37	6.79	6.43	3.98	4.32

As can be seen in Table 2, the common logarithm of the average number of organisms per gram of tissue present in the treated and non-treated wounds decreased slightly for all five animals over the first 4 days. In the treated wounds, the mean log of

organisms/gm decreased dramatically between days 4 and 5. The mean log of organisms/gm within the non-treated wounds increased during the same period. Using the traditional baseline of 10^5 organisms/gm to
5 define infection, the data of Table 2 shows that the average treated wound was disinfected after four days of treatment while the average non-treated wound was still infected after 7 days.

10 **Example 3 - Treatment of Burns**

Use of reduced pressure appliances upon burns has been found to retard the progression of partial thickness burns into full thickness burns. A partial thickness burn is a burn in which the depth of cell
15 death due to thermal trauma does not extend below the level of the deepest epidermal structures (i.e., the base of hair follicles, sweat glands, sebaceous glands, etc.). A burn that is initially a partial thickness burn will often deepen and progress into a
20 full thickness burn due to insufficient blood circulation to the epidermal cells beneath the partial burn.

Example 3A

25 The backs of five 15 kg pigs were shaved and scrubbed for surgery. A 1.5 inch diameter brass rod was heated to 190°C in an oil bath. The rod was pressed onto the pig's skin for 15 seconds following a well-known technique of relating depth of burn to time
30 and temperature. Three burns were created over the spine of each pig, separated by 5 cm intervals. Suction apparatus cups of the configuration shown in FIGS. 2 and 11 were placed over two of the burns, with silver sulphadiazine (Silvadine) cream, the standard
35 antibiotic cream applied to human burns prior to

excision of burned tissue, applied to the third.
Cefaxolin (Kefzol) (500 mg) was administered
intramuscularly (antibiotic). Suction (2-6 pounds
vacuum) was applied to one of the cups. A small (2
5 mm) punch biopsy was taken of the wounded area and
examined histologically for depth of burn.

Biopsies were analyzed by a dermatopathologist
who was not told the nature of the study. It was
concluded that the suctioned tissue specimens were
10 healthier and healing more quickly than non-suctioned
specimens.

Example 3B

A set of 2 cm diameter standardized depth partial
15 thickness burns were created by pressing a heated
metal rod to each side of five anesthetized pigs to
create 16 burns on each side of each pig. Reduced
pressure appliances of the type shown in FIGS. 2 and
11 were secured over each of the burns on the left
20 side of each animal and a continuous pressure of 6 in.
Hg was supplied to the reduced pressure appliances.
The animals were anesthetized daily, and elliptical
full-thickness biopsies extending from non-injured
tissue, through the center of each burn, and into non-
25 injured tissue were harvested, fixed in formalin,
processed for histological analysis and stained with
Hematoxylin/eosin and Gomori's trichrome. The
histologic slides were then given to a
Dermatopathologist for blind determination of burn
30 depth according to the Breslow Local Scale of maximum
depth of cell death below the surface of the skin.

The Breslow Level (maximum total depth) for the
burns treated by reduced pressure was 0.095 mm. The
maximum depth of the burns which were not treated by
35 reduced pressure was 0.885 mm. The use of reduced

pressure appliances thus resulted in a 112% reduction in the maximum depth of burn progression.

5 **Example 3C - Treatment of Burn With Negative Pressure**

 Patient B. is admitted with second and third degree burns over the face and upper extremities, including both hands, as a result of a house fire. A large mitten-shaped reduced pressure appliance of the general type shown in FIGS. 1 and 10 is placed over the patient's right hand, with open cell foam inserts placed between the fingers to apply reduced pressure to the interdigit spaces. Three pounds of vacuum is applied cyclically in a pattern of five minutes on, 5 minutes off. The appliance is changed on a three times per week schedule. Treatment is continued until the necrotic tissue sloughs off or is excised, followed by split thickness skin graft placement.

20 **Example 4 - Treatment of Flaps**

 In order to determine the effect of reduced pressure application upon skin flap survival, five 15 kg Chester pigs were obtained and acclimated for 1 week as described previously. Two dorsally-based 3 cm by 12 cm flap outlines were drawn using indelible ink on each side of the pigs, leaving 6 cm between each flap. The flaps were assigned to one of four groups as follows:

 (1) Dual-treated flaps are flaps that were exposed to reduced pressure both prior to and following surgery;

 (2) Pre-treated flaps are flaps that were exposed to reduced pressure prior to surgery, but were not exposed to reduced pressure after surgery;

 (3) Post-treated flaps are flaps that were exposed to reduced pressure following surgery; and

(4) Control flaps are flaps that were not exposed to reduced pressure either pre- or post-surgery.

The pre-treated flaps were initially treated by covering an area surrounding one of the flap outlines on the left side of each animal with a reduced pressure appliance of the type shown in FIGS. 1 and 10 having a large piece of open cell foam into which a tube was inserted. The foam was covered and sealed to the flap area with impermeable adherent sheeting. A reduced pressure of 7 pounds was then continuously applied to the area for 7 days.

On the day of surgery, each pig was sedated as previously described and anesthesia was maintained by 1% halothane. Two 3 cm by 12 cm dorsally based flaps were created on each side of the pig following the flap outlines. The flaps were created at a depth immediately below the *panniculus carnosus* (a subcutaneous muscle layer). The flaps were raised and then sutured back in place with single, interrupted sutures of 3-0 nylon. The reduced pressure appliances were then placed over the anterior flaps on each side of the animal. A reduced pressure of 5-7 pounds was continuously applied to the anterior flaps. Each suction tube ran from the appliances on the animals upward through a pulley suspended over the pens and down to a vacuum trap bottle to collect any liquid exudate. A hose was connected from each vacuum trap bottle to a vacuum pump to supply the reduced pressure to the appliances. The animals had free access to all areas of the pen.

The animals were anesthetized 72 hours after surgery and the appliances were removed. Photographs of each side of the animals were taken, and tracings of the flaps (and encompassing any discolored areas) were made on acetate to allow for planimetric

calculation of percent survival. The appliances were then replaced and reduced pressure re-applied. This routine was continued at 48 hour intervals until no further necrosis or healing of the flaps was observed.

5 The distal portions of all flaps were discolored 72 hours post surgery, with the flaps exposed to reduced pressure being lighter in color. The distal ends of all flaps appeared to necrose and an eschar formed over the distal portion of each flap. Over
10 time the eschar spontaneously desquamated, exposing the outline of the original flap. The eschar over the control and pre-treated flaps consistently desquamated sooner than the post-treated and the dual-treated
15 flaps. The control flaps had contracted to a Y shape which was evident after the eschar had desquamated. The dual-treated flaps had contracted slightly and appeared as long, thin rectangles after dislodgement of the eschar. The pre-treated flaps and post-treated
20 flaps were intermediate between the control and dual-treated flaps in regard to flap contraction.

Dual-treated flaps exhibited the greatest survival in terms of percent retention (72.2%) of the original flap size. The post-treated flaps had the second greatest survival (67.4%). The pretreated
25 flaps had the third most flap survival (64.8%). The control flaps had the least flap survival (51.2%). All treated flaps (dual-treated; pre-treated; and post-treated) exhibited significantly greater surface area survival than the control flaps. The
30 dual-treated flaps had significantly greater surface area survival than either the pre-treated or post--treated flaps. The pre-treated flaps were not significantly different than post-treated flaps in regard to flap survival.

35

Example 5 - Treatment of Decubitus Ulcers

Application of reduced pressure was tested upon chronic decubitus ulcers and was found to be effective in the treatment thereof. Necrotic soft tissue was removed from the ulcers prior to placement upon the treatment site of a reduced pressure appliance of the type described in connection with FIGS. 1 and 10. Treatment of decubitus ulcers was tested using both continuous and cyclic application of reduced pressure. It was found that cyclic application of reduced pressure was both more effective and produced less discomfort for the patients than continuous application. Cyclic application of reduced pressure was conducted according to an application schedule of 5 minutes of suction followed by 5 minutes of non-suction. In 15 patients tested, successful treatment required from 2 to 13 weeks. Thirteen of the ulcers healed completely and every ulcer treated demonstrated progressive decrease in size during treatment. The following case histories demonstrate the manner in which various pressure sores were treated:

Case 1 - A 39 year-old male T4 paraplegic had suffered from multiple recurrent pressure sores over a period of 8 years. He had been treated for a trochanteric decubitus with a tensor fascia lata flap which had developed a recurrent ulcer in the center of the flap 4 months prior to presentation. The ulcer was debrided of necrotic tissue to non-involved periosteum resulting in a wound measuring 12 cm by 5 cm with a depth of 5 cm. During the course of 4 weeks of cyclic reduced pressure application, the wound progressively closed and spontaneously re-epithelialized. Reduced pressure of 5 in. Hg below atmospheric pressure was applied cyclically with 5 minute intervals of applied pressure followed by 5

minute intervals with no applied pressure. The wound remained healed more than 5 months after treatment.

Case 2 - A 45 year old male paraplegic suffered from a recurrent right ischial fossa pressure sore and abscess prior to treatment. Debridement of the wound was carried out with partial ischial resection. A week later, a re-advancement of the V-Y biceps femoris flap and rotation gluteus flap was performed. Six days later, the wound dehiscd and the patient developed bilateral pneumonia requiring ventilatory support. The flap became progressively edematous and firm and resisted all efforts at mobilization. At this point, reduced pressure treatment providing continuous, non-cyclic suction or a vacuum at approximately five 5 in. Hg below atmospheric pressure was initiated. A total of 2 liters of fluid was removed by the reduced pressure appliance during the first 72 hours of treatment. Intravenous fluids were administered to replace the fluid removed from the wound. The appliance was replaced and the wound was examined three times each week. Treatment was continued for a total of six weeks during which the flap became progressively less indurated, granulation tissue formation rapidly progressed, the edges of the wound came into approximation, and the wound was healed completely.

Case 3 - A 51 year-old T1 paraplegic had multiple previous pressure sores culminating in bilateral asynchronous hip disarticulations and bilateral total thigh flaps. Seven months prior to admission, he developed a 7 cm by 23 cm pressure sore over the remnants of both ischia. Bone was exposed and no tissue was available for wound closure. Dressing changes over a period of three months had failed to improve the wound. A reduced pressure appliance was

then secured to the wound. During the first 3 weeks of treatment, reduced pressure of 5 in. Hg below atmospheric pressure was continuously applied. For the following 9 weeks, reduced pressure was applied cyclically in 5 minute intervals. The appliance was replaced every three days during treatment. In the course of the treatment, the wound first granulated to cover the bone completely and then the wound re-epithelialized from the margins. After 12 weeks of the treatment, a 2 cm by 5 cm scrotal flap was used to cover the midline area of the wound. The wound has remained stable beyond 6 months after treatment.

Example 6 - Treatment of Dehisced Incisions

A 50 year old debilitated white male who had undergone a colostomy through a midline laparotomy was re-admitted to the hospital for wound dehiscence and evisceration following an upper respiratory infection. He was taken immediately to the operating room and the abdominal wall was closed with Prolene mesh. Six weeks after placement of the Prolene mesh, the wound was still open and measured 28 cm by 23 cm. Only sparse granulation tissue had grown through the Prolene mesh during the six weeks. At this time a large reduced pressure appliance of the type shown in FIG. 5 was placed on an underlying porous aquaplast sheet (WFR/Aquaplast Corp., Wycoff, NJ 07481) over top of the Prolene mesh/wound surface and the space closed with a covering tent of Ioban. A continuous vacuum of 5 in. Hg below atmospheric pressure was applied. The appliance was changed three times per week. After 8 days of treatment, granulation tissue had grown through and totally covered the Prolene mesh. Two days later, the patient was taken to the operating room, where the surrounding tissue was

undermined and used to close 75% of the wound. Split thickness skin grafts were used to cover the remainder of the wound, and were placed on the bed of granulation tissue. There was 80% take of the grafts, and the remaining areas healed spontaneously with wet to dry dressing changes. The wound has remained stable 16 months after surgery.

Example 7 - Treatment of Infected Wound

Infected wounds have been successfully treated via application of reduced pressure as described in the following cases:

Case 1 - A 39 year old white male sustained severe avulsive trauma to his left lower extremity in a motor vehicle accident 10 years prior to presentation. He presented with a ten year history of chronic osteomyelitis and a 3 cm diameter open ulcer with exposure of bone of his left lateral malleolus. He had previously undergone 7 local surgical procedures to attempt closure of the wound. An arteriogram demonstrated a one vessel foot with diffuse atherosclerosis and post traumatic changes. The extremity was debrided of necrotic soft tissue and all involved bone saucerized. The patient was placed on a five week course of antibiotics. The day after debridement, a reduced pressure device of the type shown in FIGS. 2 and 11 was applied over the wound and a reduced pressure of 5 in. Hg below atmospheric pressure was applied. The device was changed on a three times per week schedule. After 14 days of treatment, the wound was smaller and filled with granulation tissue which completely covered the previously exposed bone. A split thickness skin graft was placed over the wound and healed primarily. The wound has been stable for 13 months with no recurrence

of osteomyelitis or tissue breakdown.

Case 2 - A 51 year old white male T8 paraplegic was admitted to the hospital for an infected left trochanteric pressure sore which had been present for one year and measured 4 cm by 6 cm. The patient had previously undergone multiple procedures for treatment of this condition including a V-Y advancement flap 4 months prior to presentation. A scan revealed possible chronic osteomyelitis of the left femur. It was decided to treat the potential osteomyelitis with a five week course of IV antibiotics. The wound was debrided, then treated using a reduced pressure appliance of the type shown in FIGS. 1 and 10 for 6 weeks with cyclical reduced pressure (5 in. Hg below atmospheric pressure; 5 minutes on/5 minutes off). The wound rapidly granulated and decreased in size. After 6 weeks the wound had closed and the patient discharged. The patient was readmitted 1 month later with a draining sinus tract to the bone. The previously scanned head of the left femur was resected and the wound closed primarily over drains. The wound healed without further problems.

**Example 8 - Chronic Open Wound Secondary to Stasis
Ulcers**

A 45 year old black female patient with a 10 year history of bilateral stasis ulcers of the pretibial area was presented with bilateral 10 cm by 15 cm infected ulcers with exposed fascia. Two previous attempts at skin grafting in the previous year had failed. The patient was treated using a reduced pressure appliance of the type shown in FIGS. 1 and 10 for 14 days with cyclical (5 minutes on/5 minutes off) reduced pressure of approximately 5 in. Hg below atmospheric pressure. After 14 days treatment, quantitative bacterial counts of both ulcers were

below 102 bacteria/gram tissue, and both ulcers appeared as healthy granulating beds. Split thickness skin grafts were then applied and exhibited 100% take. The patient is ambulating, and the wounds have
5 remained healed for 2 months, which is the longest the wounds had been healed in the last 10 years.

Example 9 - Enhancement of Blood Flow

It is believed that the efficacy of reduced
10 pressure appliances in such treatments as have been described is due at least in part to enhancement of blood circulation within the treated wounds. In order to determine the effect of pressure application upon
15 blood flow, a laser doppler needle probe was inserted into tissue adjacent to a pressure sore. A baseline flow level was recorded for thirty minutes. Then, the relative blood flow level was measured while a reduced pressure corresponding to 5 in. Hg below atmospheric
20 pressure was continuously applied to the wound for 30 minutes using a reduced pressure appliance of the type shown in FIGS. 1 and 10. During continuous reduced pressure application, the relative blood flow level was only slightly higher than the baseline level.

Then the supply of reduced pressure to the
25 appliance was cycled on and off at equal 5 minute intervals. During the "off" portions of the cycle, the relative blood flow level was twice as high as the baseline level. It is postulated that the increased blood flow during the off cycle is likely due to a
30 "rebound" phenomenon. During the "on" cycle, blood is drawn toward the wounded tissue from both the venous and arterial branches of the vascular network in the vicinity of the wound. During the "off" cycle, this blood is transported toward the venous branch of the
35 vascular network at a rate that is greater than would

have been observed in the absence of the preceding
"on" cycle.

5 The terms and expressions which have been
employed are used as terms of description and not of
limitation and there is no intention in the use of
such terms and expressions of excluding any
equivalents of the features shown and described, or
portions thereof, but it is recognized that various
modifications are possible within the scope of the
10 claimed invention.

What is claimed is:

1. An appliance for administering a reduced pressure treatment to a wound comprising:

(a) an impermeable cover for covering and enclosing the wound and for maintaining reduced pressure at the site of the wound;

(b) a seal for sealing said cover to tissue surrounding the wound; and

(c) reduced pressure supply means for connection to a source of suction for supplying said reduced pressure beneath the cover.

2. The appliance as recited in claim 1 comprising a screen for preventing overgrowth of wound tissue, said screen being locatable between said wound and said cover.

3. The appliance as recited in claim 2 wherein said screen comprises a porous sheet.

4. The appliance as recited in claim 1 wherein said reduced pressure supply means comprises a screen having an open cell foam and said reduced pressure supply means includes a segment of tubing embedded within said screen.

5. The appliance as recited in claim 1 wherein said cover is sufficiently rigid to protect the wound from impact and said reduced pressure supply means comprises a suction port on said cover.

6. The appliance as recited in claim 3 wherein said seal includes a cuff around the periphery of said cover for preventing said cover from digging into the skin during the treatment.

7. The appliance as recited in claim 1 wherein said seal includes an adhesive material on the cover for securing said cover to the tissue surrounding the wound.

8. An apparatus for treating a wound comprising:
(a) a vacuum system for producing a reduced pressure; and

(b) a reduced pressure appliance operably connected with said vacuum system for applying said reduced pressure to the wound, the appliance including:

(i) an impermeable cover for covering and enclosing the wound and for maintaining reduced pressure at the site of the wound;

(ii) a seal for sealing said cover to tissue surrounding the wound; and

(iii) reduced pressure supply means for connection with the vacuum system for supplying said reduced pressure to the wound.

9. The apparatus as recited in claim 3 wherein said vacuum system includes a collection device for collecting fluid aspirated from the wound.

10. The apparatus as recited in claim 3 wherein said collection device includes means for halting said application of reduced pressure to the wound when said fluid exceeds a predetermined quantity.

11. The apparatus as recited in claim 3 wherein said reduced pressure is from about 2 in. Hg below atmospheric pressure to about 7 in. Hg below atmospheric pressure.

12. A method of treating a wound comprising the steps of:

- (a) applying a reduced pressure to the wound; and
- (b) maintaining said reduced pressure until the wound has progressed toward a selected stage of healing.

13. The method as recited in claim 3 wherein said reduced pressure is from about 2 in. Hg below atmospheric pressure to about 7 in. Hg below atmospheric pressure.

14. The method as recited in claim 3 wherein said applying step comprises steps of:

- (a) locating an impermeable cover over the wound, said cover having a suction port;
- (b) sealing the periphery of said impermeable cover to tissue surrounding the wound; and
- (c) operably connecting said suction port with a vacuum system for producing said reduced pressure.

15. The method as recited in claim 4 further comprising the step of placing a porous screen over the wound prior to said locating step.

16. A method of treating a wound comprising the steps of:

- (a) securing an appliance for applying reduced pressure to the wound; and
- (b) providing reduced pressure to said appliance in alternating intervals of application and non-application.

17. The method as recited in claim 6 wherein said reduced pressure is from about 2 in. Hg below atmospheric pressure to about 7 in . Hg below atmospheric pressure.

18. A method of pretreating a skin flap to promote attachment of the flap to a wound comprising the step of applying reduced pressure to a region of skin tissue adjacent to the wound prior to detachment of said skin tissue adjacent to the wound to form the flap from said region of skin.

19. The appliance of Claim 1 wherein said cover comprises a flexible sheet.

20. The appliance of Claim 19 comprising support means for supporting said sheet outward from the wound.

21. The appliance of Claim 20 wherein said support means comprises a support member located between said sheet and the wound.

22. The appliance of Claim 21 wherein said support member includes a porous cup member having attachment means for connecting with said reduced pressure supply means.

23. The appliance of Claim 21 further comprising a pad between the wound and said support member for alleviating discomfort caused in the wound by said support member.

24. The appliance of claim 20 wherein said support means comprises a support member extending

outwardly over the wound and external to said sheet.

25. The appliance of claim 24 wherein said support means comprises attachment means for attaching said sheet to said support means, said attachment means having a connecting member for connecting with said reduced pressure supply means for providing said reduced pressure beneath said sheet, and said support member comprising a plurality of leg members attached to said attachment means for holding said attachment means and said sheet outward from the wound.

26. The appliance of Claim 5 further comprising a screen adapted to prevent overgrowth of the wound for placement at a location between the wound and said cover and securable in said location by the periphery of said cover.

27. The appliance of Claim 26 wherein said screen comprises a sheet-like mesh.

28. The appliance of Claim 26 wherein said seal includes an adhesive material on the cover for adhering to tissue surrounding the wound and a seal member at least partially overlying said cover.

29. The apparatus of claim 8 wherein said reduced pressure supply means comprises a length of tubing connected between said vacuum system and said cover and wherein said vacuum system comprises:

- (a) a vacuum pump connected with said tubing; and
- (b) a filter for preventing said pump from venting micro-organisms aspirated from the wound.

30. The apparatus of Claim 29 wherein said filter is connected along said tubing between said pump and said cover for preventing contamination of said pump.

31. The apparatus of claim 8 wherein said vacuum system comprises control means for cyclically controlling said production of reduced pressure in alternating periods of production and non-production of reduced pressure.

32. The apparatus of Claim 10 wherein said reduced pressure supply means comprises a length of tubing, said collection device comprises an aspirating container connected along said length of tubing between said vacuum system and cover, and said halting means comprises a flotation valve within said aspirating container for blocking said tubing when a predetermined amount of fluid is collected within said container.

33. The apparatus of Claim 10 wherein said collection device comprises an expandable chamber and said means for halting said application of reduced pressure comprises sensing means for sensing expansion of said expandable chamber, said sensing means operatively connected with said vacuum system so that said reduced pressure is halted when a predetermined expansion of said expandable chamber is sensed by said sensing means.

34. The apparatus of claim 10 wherein said reduced pressure supply means comprises a length of tubing and said halting means comprises a filter along said tubing, said filter having pores that block the

supply of reduced pressure via said tubing when said pores are filled with said fluid.

35. The method of Claim 12 wherein said maintaining step is conducted in alternating periods of application and non-application of the negative pressure.

36. The method of claim 35 wherein each of said alternating periods is about 5 minutes.

37. The method of claim 12 wherein said selected stage of healing is cessation of partial thickness burn progression.

38. The method of claim 12 wherein said selected stage of healing is a reduction in bacterial density in the wound.

39. An assembly for supplying reduced pressure beneath an impermeable cover sealed to tissue surrounding a wound, the assembly comprising:

(a) an open cell foam screen for applying the reduced pressure to the wound; and

(b) a tube member embedded in said screen for extending from beneath the cover and for supplying the reduced pressure to said foam.

40. The assembly of Claim 39 wherein said tube member has a side port within the foam for promoting substantially uniform application of reduced pressure to the wound.

41. The assembly of Claim 39 wherein said foam screen is adapted to be conformed to the shape and

size of the wound.

42. A device for promoting closure of a wound comprising:

(a) an impermeable deformable cover for placement over the wound;

(b) an adhesive layer on the cover for forming a seal between said cover and tissue surrounding the wound;

(c) support means for supporting said cover outward from the wound forming an enclosed volume bounded by said cover and the wound and tissue surrounding the wound; and

(d) supply means for supplying reduced pressure to said enclosed volume and for deforming said cover so as to exert tension upon the tissue surrounding the wound.

43. The device of Claim 42 wherein said support means comprises a support member locatable within said enclosed volume.

44. The device of Claim 43 wherein said support member comprises a porous cup member.

45. The device of Claim 42 wherein said support means comprises a support member locatable external to said enclosed volume.

46. The appliance of claim 45 wherein said support means comprises attachment means for attaching said cover to said support means, and said support means comprises a plurality of leg members for supporting said cover out of contact with the wound.

47. A method of promoting attachment of a skin graft onto a wound comprising steps of:

- (a) attaching the graft to the wound, and
- (b) applying reduced pressure to the graft to promote blood circulation within the graft.

48. The method of claim 47 wherein the graft is a skin flap, the method further comprising steps of:

- (a) applying reduced pressure to a region of skin adjacent to the wound, and
- (b) forming the flap by detaching skin from said region prior to said attaching step.

49. The method of claim 47 comprising steps of:

- (a) applying reduced pressure to a region of skin for use as the skin graft; and
- (b) forming the graft by detaching skin from said region.

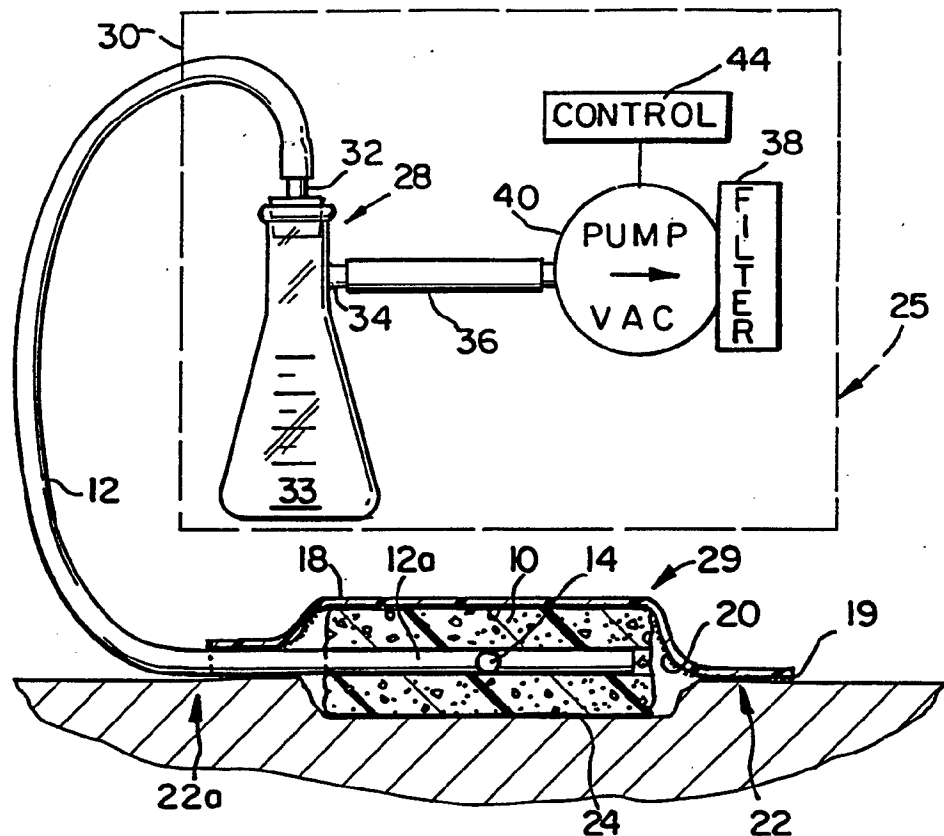

FIG. 1

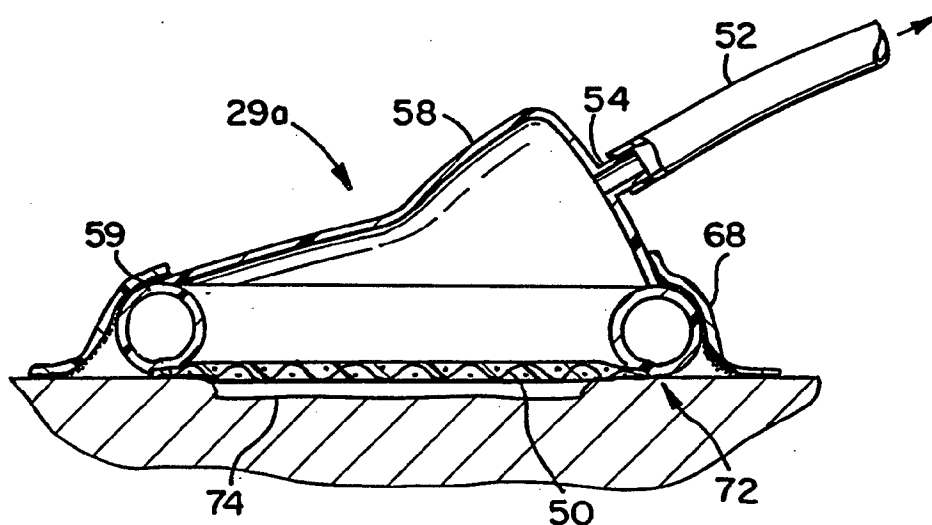

FIG. 2

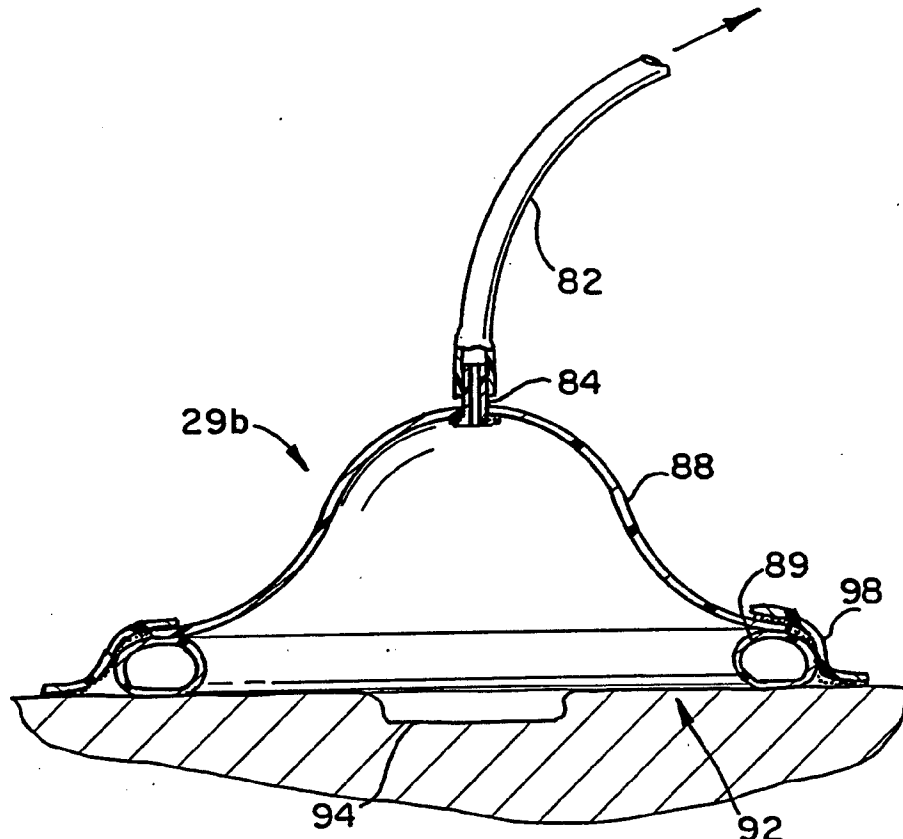

FIG. 3

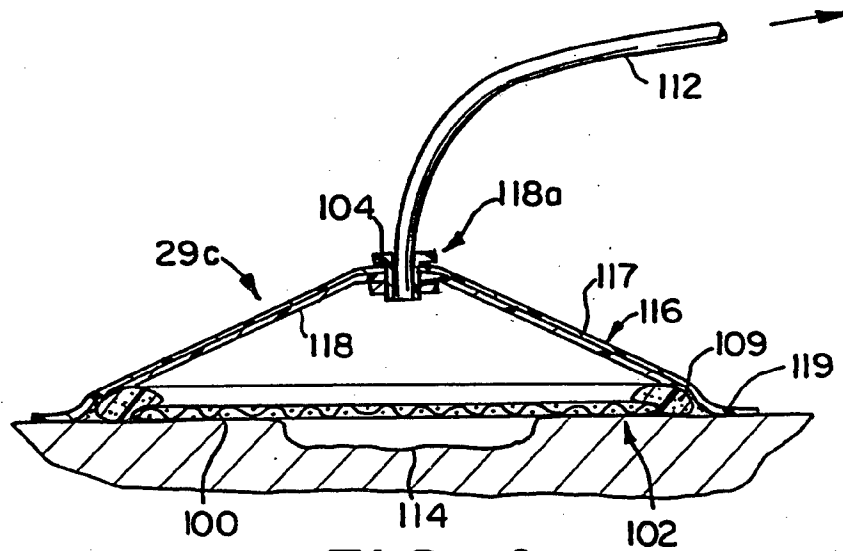

FIG. 4

SUBSTITUTE SHEET (RULE 26)

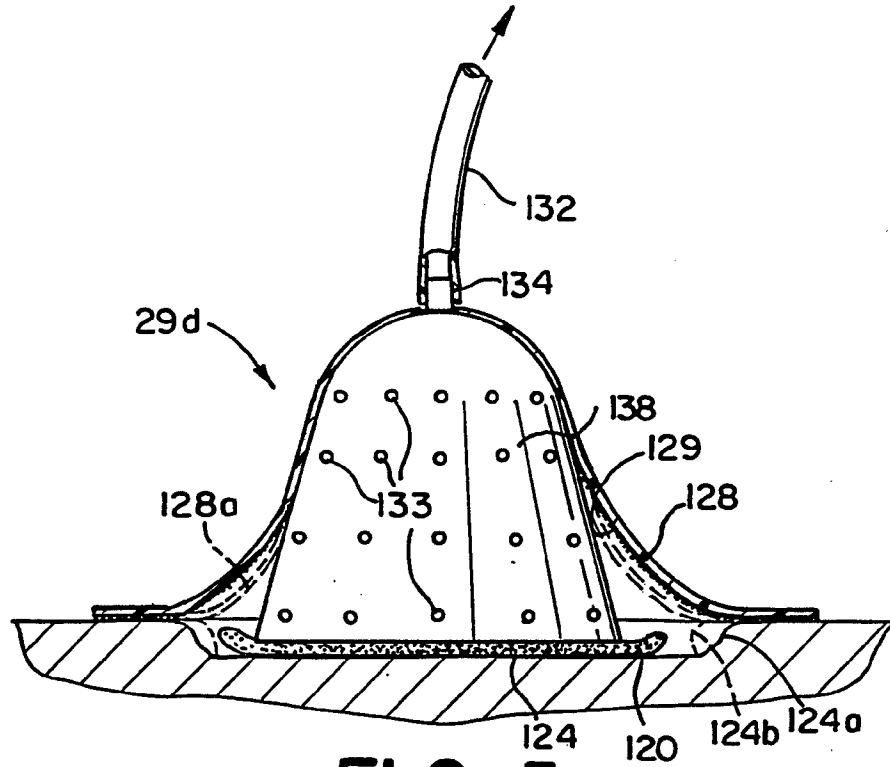

FIG. 5

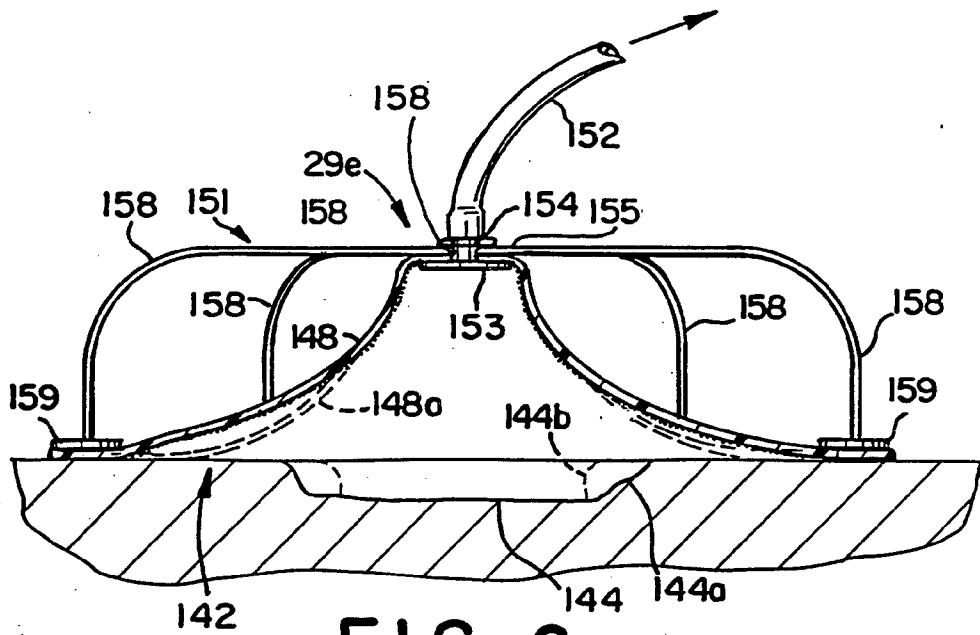

FIG. 6

SUBSTITUTE SHEET (RULE 26)

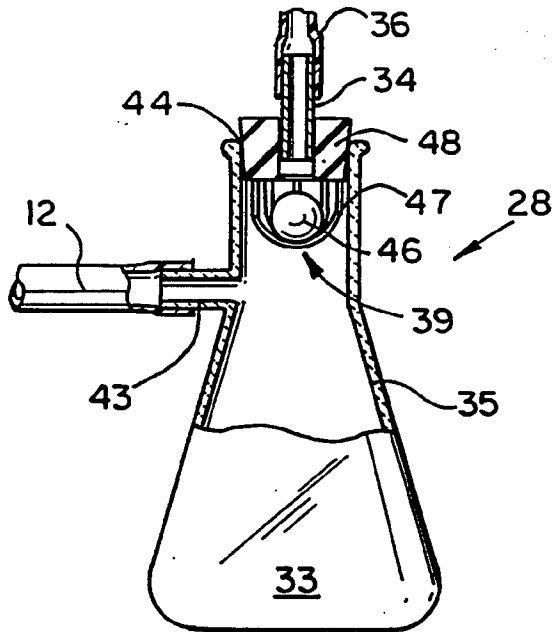

FIG. 7

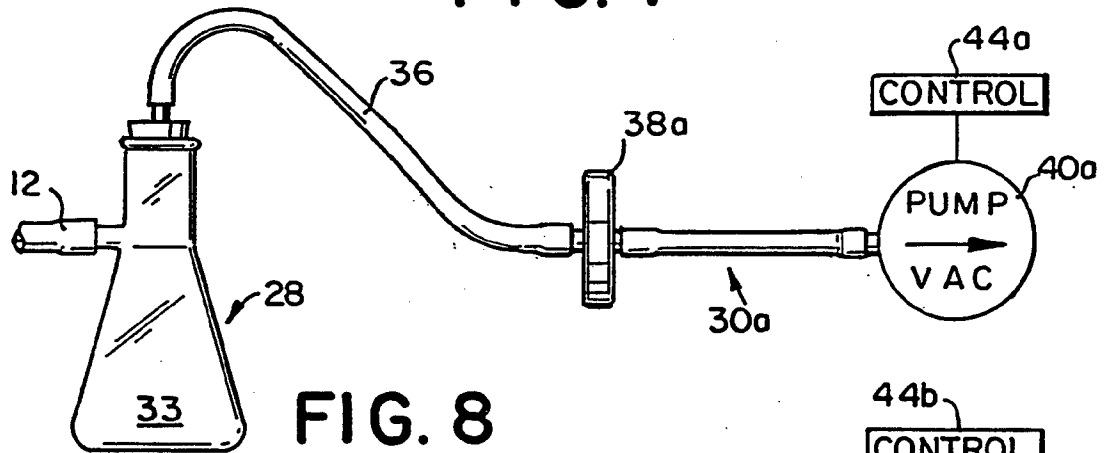

FIG. 8

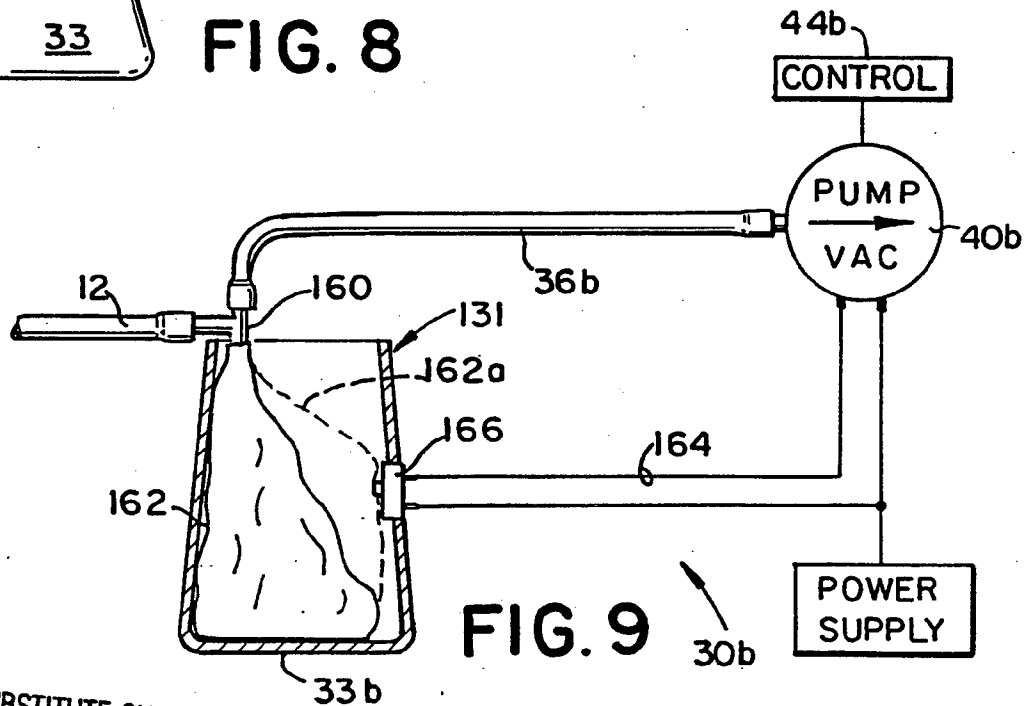

FIG. 9

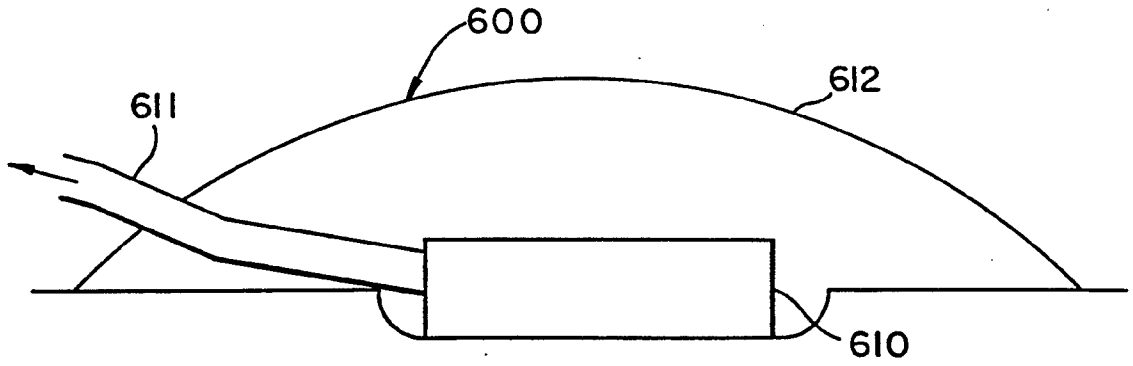

FIG. 10

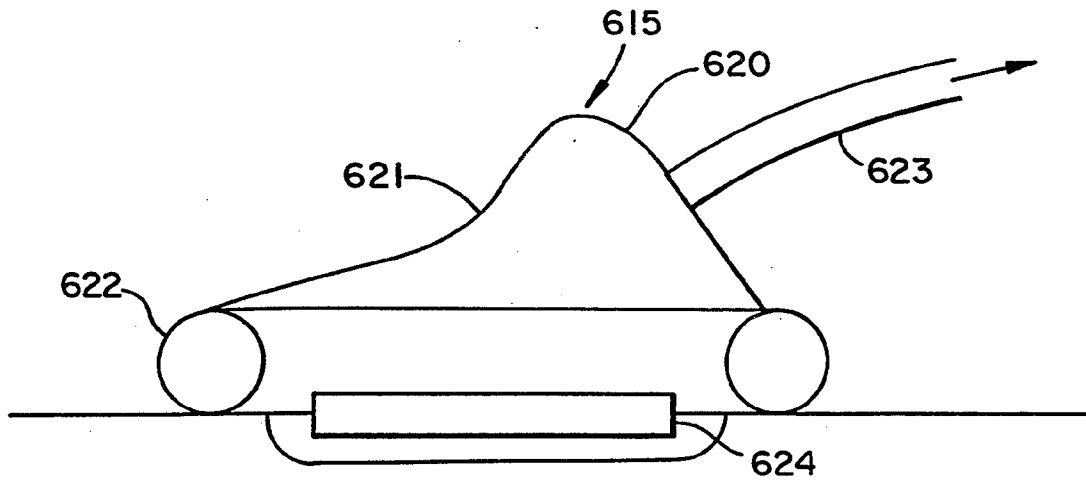

FIG. 11

INTERNATIONAL SEARCH REPORT

International application No.
PCT/US94/02409

A. CLASSIFICATION OF SUBJECT MATTER IPC(5) :A61B 19/00 US CL :128/897 According to International Patent Classification (IPC) or to both national classification and IPC		
B. FIELDS SEARCHED Minimum documentation searched (classification system followed by classification symbols) U.S. : 128/897-898; 602/42-53 Documentation searched other than minimum documentation to the extent that such documents are included in the fields searched NONE Electronic data base consulted during the international search (name of data base and, where practicable, search terms used) NONE		
C. DOCUMENTS CONSIDERED TO BE RELEVANT		
Category*	Citation of document, with indication, where appropriate, of the relevant passages	Relevant to claim No.
X ---- Y	US, A, 3,874,387, (BARBIERI), 01 April 1975. See entire document.	1, 5, 8-9, 12, 14 ----- 6-7, 11, 13
Y	US, A, 4,834,110, (RICHARD), 30 May 1989. See entire document.	6-7, 11, 13
X	US, A, 4,382,441, (SVEDMAN), 10 May 1983. See entire document.	39-41
<input type="checkbox"/> Further documents are listed in the continuation of Box C. <input type="checkbox"/> See patent family annex.		
* Special categories of cited documents:		*T* later document published after the international filing date or priority date and not in conflict with the application but cited to understand the principle or theory underlying the invention
A document defining the general state of the art which is not considered to be part of particular relevance		*X* document of particular relevance; the claimed invention cannot be considered novel or cannot be considered to involve an inventive step when the document is taken alone
E earlier document published on or after the international filing date		*Y* document of particular relevance; the claimed invention cannot be considered to involve an inventive step when the document is combined with one or more other such documents, such combination being obvious to a person skilled in the art
L document which may throw doubts on priority claim(s) or which is cited to establish the publication date of another citation or other special reason (as specified)		*&* document member of the same patent family
O document referring to an oral disclosure, use, exhibition or other means		
P document published prior to the international filing date but later than the priority date claimed		
Date of the actual completion of the international search 18 APRIL 1994	Date of mailing of the international search report MAY 02 1994	
Name and mailing address of the ISA/US Commissioner of Patents and Trademarks Box PCT Washington, D.C. 20231 Facsimile No. (703) 305-3590	Authorized officer <i>John P. Lacyk</i> FOR JOHN P. LACYK Telephone No. (703) 308-0858	